

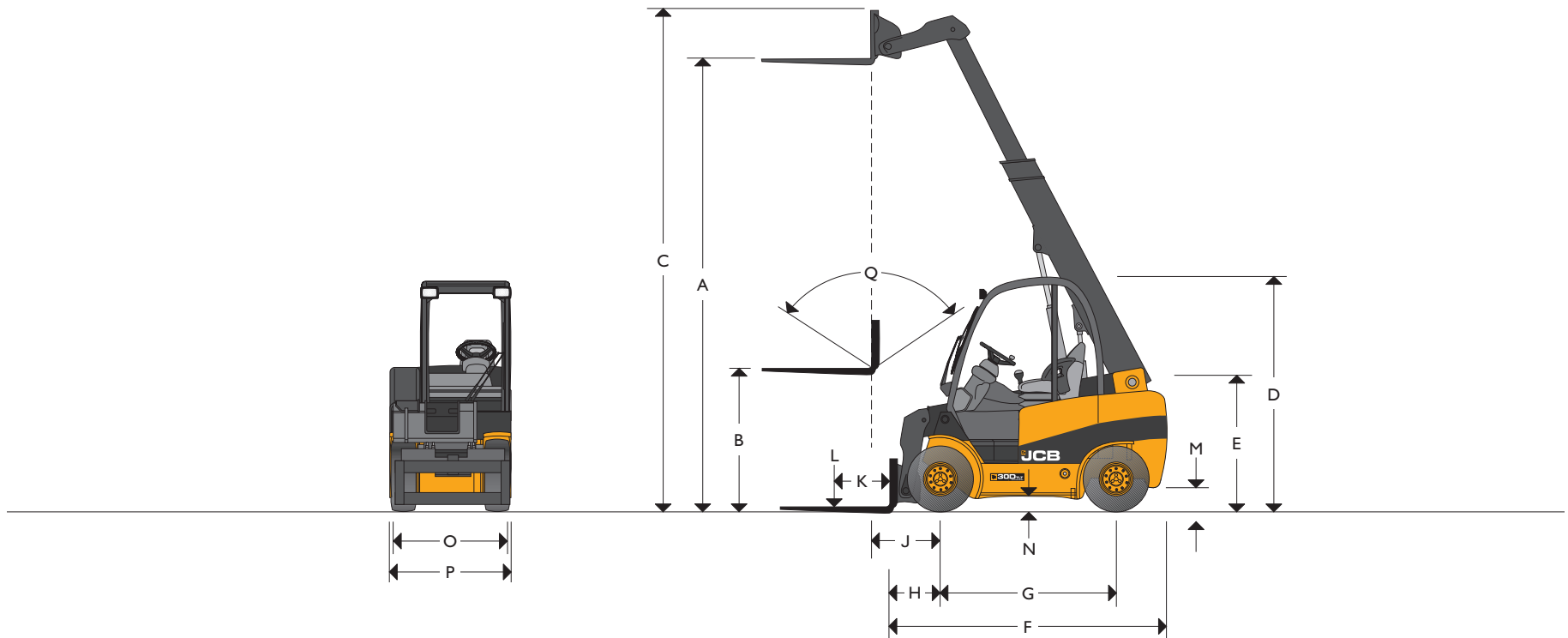

ENGINE FUEL TYPE: DIESEL    LIFT CAPACITY: UP TO 6,600 lb    MAX HORSEPOWER: 50 hp Tier III Engine



STATIC DIMENSIONS

Model		TLT 30D
A	Lift Height	in (mm) 161 (4100)
B	Free Lift (standard)	in (mm) 55.5 (1410)
C	Height Boom Extended	in (mm) 182 (4625)
D	Height of Overhead Guard (std/low)	in (mm) 87/83 (2205/2105)
E	Height of Operator's Seat (std/low)	in (mm) 43/42 (1092/1067)
F	Length to Fork Face	in (mm) 108 (2750)
G	Wheelbase	in (mm) 67 (1700)
H	Distance from c/l of Front Axle to Fork Face (at ground level)	in (mm) 21 (515)

Model		TLT 30D
J	Distance from c/l of Front Axle to Fork Face (at full height)	in (mm) 29 (715)
K	Load Center	in (mm) 20 (500)
L	Lift Capacities (with sideshift)	lb (kg) 6600 (3,000)
M	Ground Clearance (lowest point)	in (mm) 5.1 (130)
N	Ground Clearance Wheelbase Center	in (mm) 6 (155)
O	Fork Carriage Width	in (mm) 47 (1194)
P	Maximum width of Machine	in (mm) 50 (1270)
Q	Carriage Tilt Total f/b Variable Through Lift Arc	degrees 111



## GENERAL SPECIFICATION

Model	TLT 30D	
Engine Type	Diesel	
Emission Certification	EPA Tier III (EU Stage 3)	
Engine Manufacturer	Perkins	
Engine Model	404 2.2	
Engine Output (gross power)	hp (kW)	50 (37)
Rated rpm	2600	
Number of Cylinders	4	
Cubic Capacity	in <sup>3</sup> (cm <sup>3</sup> )	134 (2200)
Working Pressure for Attachments	psi (bar)	2465 (170)
Oil Flow for Attachments	gal/min (l/min)	19 (70)
Max Reach Ground Level (24 in load center)	in (mm)	87 (2230)
Max Reach Boom Horizontal (24 in load center)	in (mm)	93 (2390)
Turning Radius	in (mm)	98 (2489)
Aisle Width 90° Stacking	in (mm)	174 (4419)
Weight Unladen	lb (kg)	10,780 (4900)
Travel Speed (standard)	mph (km/h)	12 (20)
Gradability (laden/unladen)	%	25 / 21
Transmission	TCR Hydro	
Park Brake Type	Hand	
Bucket Rated Capacity	ft <sup>3</sup> (m <sup>3</sup> )	21 (0.6)
Bucket Struck Capacity	ft <sup>3</sup> (m <sup>3</sup> )	17.5 (0.5)
Bucket Dump Height (30°)	in (mm)	94 (2400)
Bucket Rollback Angle at Ground	degrees	37
Bucket Width	in (mm)	54 (1385)
Tires PPS (semi-solid), L (pneumatic)	PPS / L	
Tire Size Front (standard)	27 x 10 x 12	
Tire Size Rear (standard)	6.50 x 10	

## STANDARD FEATURES

- Versatile telescopic two-piece boom.
- Superb forward visibility.
- Information display center (I.D.C.) complete with warning lights, hourmeter.
- JCB 'TCR' torque converter response transmission.
- Comfortable operator's enclosure (structure fully meets international safety standards for (ROPS) Roll-Over Protection and (FOPS) Falling Object Protection).
- Seat belt and hip restraint on fully adjustable seat.
- Self leveling forks.
- Hose-burst-check valves on tilt, lift, and extension ram circuits.
- Front screen guard.
- Operator's daily checks completed via single easy-access panel, and excellent service access to major components.
- Battery isolator.
- Security etched glazing.
- Working lights front and rear.
- 111 degree carriage tilt.
- Bucket mode switch.
- Slim line high visibility boom for maximum fork tip visibility.

## OPTIONS

Over 100 build options, including:

- Choice of pneumatic or foam filled tires.
- Lightweight re-handling bucket.
- Bagezee 'trapdoor' bucket for loading/filling big bags in single operation.
- Quick disconnect system for easy changing between attachments.
- Sideshift carriage and various forks.
- Range of load guards, attachments, exhaust purification systems, etc.
- Various operator environments: safety mesh to operator's right, glazing to front/rear/top. Full cab with door and heater or air conditioning.
- Low-height cab (for cab containers check height and floor loadings).
- Vinyl or fabric seat in high/standard/low versions.
- Roadlights.
- Flow divider.

LIFT CAPACITIES

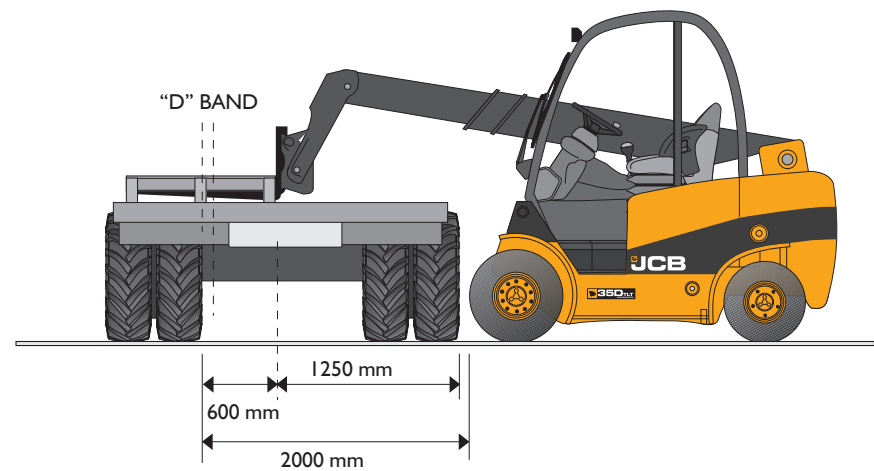
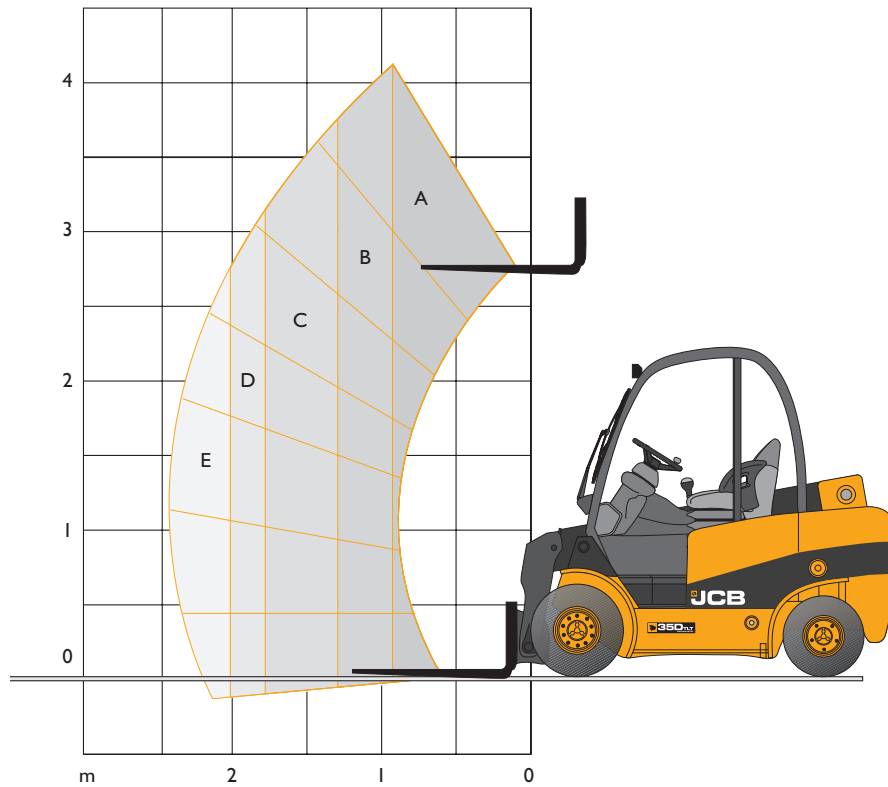

Capacity bands	TLT 30D
A	6,600 lb
B	5,500 lb
C	4,400 lb
D	3,850 lb
E	3,300 lb



## A GLOBAL COMMITMENT TO QUALITY

JCB's total commitment to its products and customers has helped it grow from a one-man business into one of the world's largest manufacturers of backhoe loaders, crawler excavators, wheeled excavators, telescopic handlers, wheeled loaders, dump trucks, rough terrain fork lifts, industrial fork lifts, mini/midi excavators, skid steer loaders and tractors.

By making constant and massive investments in the latest production technology, the JCB factories have become some of the most advanced in the world.

By leading the field in innovative research and design, extensive testing and stringent quality control, JCB machines have become renowned all over the world for performance, value and reliability.

And with an extensive dealer sales and service network in over 150 countries, we aim to deliver the best customer support in the industry.

Through setting the standards by which others are judged, JCB has become one of the world's most impressive success stories.



JCB Headquarters Savannah, 2000 Bamford Blvd, Savannah, GA 31322 Tel: (912) 447-2000 Fax: (912) 447-2299 [www.jcb.com](http://www.jcb.com)

JCB reserves the right to change specifications without notice. Illustrations shown may include optional equipment and accessories. The JCB logo is a registered trademark of J C Bamford Excavators Ltd.